



Page: 1	<b>ARM 3.0 Data Sheet</b>	Document Number: <b>i04207</b>
Total Pages: 8	Date: 2014/11/17	Revision: <b>02</b>



## 1. PRODUCT DESCRIPTION

The Advanced Robotic Manipulator (ARM) 3.0 is a six-axis robotic arm with an open control interface to allow simple implementation into other projects. Each joint is commanded to position via RC PWM signals. Since this is the same signal used to control hobby servos, there is a wide range of devices in the marketplace that can be interfaced to this ARM product. Carbon fiber segments and CNC machined aircraft grade aluminum make the ARM 3.0 a robust unit. With a reach diameter of over 2 meters and ability to lift 4.5kg (10 pounds) it is a very capable ARM value.

### 1.1 IMPROVEMENTS OVER ARM 2.0

The ARM 3.0 leverages the success of the ARM 1.0 and 2.0 projects. It supersedes ARM 2.0 and provides improved performance. Better reliability and more lifting capacity are notable improvements as well as better optimized ranges of travel for each joint. Absolute encoder feedback at the joints improves control and position feedback resolution and linearity. The proven CNC machined aluminum and carbon fiber construction is retained.



Page: 2	<b>ARM 3.0 Data Sheet</b>	Document Number: <b>i04207</b>
Total Pages: 8	Date: 2014/11/17	Revision: <b>02</b>

## 2. APPLICATIONS

- ◆ Robotic controls research projects
- ◆ University engineering labs
- ◆ Manipulator for un-manned ground vehicles
- ◆ Robotic competitions
- ◆ Testing of products in hazardous environments

## 3. FEATURES

- 2.2 meter Reach Diameter
- Lifts 10 pounds (4.5kg) at full extension
- Total System weight of 9.25 kg (20.4 lb)
- Closed-loop position control at all 6 joints
- Holds position on lower 4 joints with power off
- Absolute, linear feedback from each joint
- Limit switches at ends of travel of linear actuators prevent accidental damage to the unit
- Rugged aluminum enclosure houses control electronics
- DB-25 connector for power and signal input
- On/Off power switch at base
- Carbon Fiber Segments
- CNC Machined Aluminum Construction
- Compatible with conventional radio control units
- Power indicator LED
- 12VDC Power
- Reverse connection protected
- 

## 4. APPLICABILITY

This document applies to the following part numbers:

Part Number	Description	DOF
i04000	ARM 3.0, Position Controlled	6
i05300	ARM 3.0, Velocity Controlled	6

Velocity controlled versions of the ARM 3.0 are available for direct human controlled applications. They do not have provision for feedback and operate in an open-loop mode.

## 5. INPUT DETAILS

### 5.1 INPUT POWER REQUIREMENTS

Input power is 12 VDC, up to 7.5A peak, tolerant of input voltages between 10VDC-14VDC. During start and stop, current requirements of the motors surge. It is strongly recommended to use an inductive load rated power supply equivalent to our i04251. See GearWurx.com for details.



Page: 3	<b>ARM 3.0 Data Sheet</b>	Document Number: <b>i04207</b>
Total Pages: 8	Date: 2014/11/17	Revision: <b>02</b>

Alternatively, a 12VDC battery is a good solution as well as long as it can handle the current surges.

## 5.2 DB-25 CONNECTOR

Electrical connection to the ARM 3.0 is made through a common DB-25 D-Sub miniature connector. The connector gender on the ARM 3.0 is female with sockets. The connector provides command signal and power connection into the ARM 3.0. The pin-out for the connector is shown in the table below.

Pin	Signal
1	DOF0
2	DOF0 GND
3	DOF1
4	DOF1 GND
5	DOF2
6	DOF2 GND
7	DOF3
8	DOF3 GND
9	TMC 4 SIG (NC)
10	TMC 4 GND (NC)
11	TMC 5 SIG (NC)
12	TMC 5 GND (NC)
13	12VDC Power
14	DOF4 SIG (Aux A)
15	0V Power Supply
16	AUX B (NC)
17	0V Power Supply
18	DOF4 GND (Aux C)
19	DOF5 SIG (Aux D)
20	DOF5 GND (Aux E)
21	12VDC Power
22	12VDC Power
23	12VDC Power
24	12VDC Power
25	12VDC Power



Page: 4	<b>ARM 3.0 Data Sheet</b>	Document Number: <b>i04207</b>
Total Pages: 8	Date: 2014/11/17	Revision: <b>02</b>

## 5.3 ADAPTER CABLE

Each ARM 3.0 includes an adapter break-out cable that connects to the DB-25 connector and provides labeled leads for power connection. It also provides RC type connectors that will connect into a hobby RC receiver or other hobby controller like the GearWurx i03813 6 channel slider controller. These connectors also connect to .1" pitch headers for PCB based microcontrollers like the Arduino and others. Each connector is labeled with DOF 0-DOF 5.

## 6. JOINT DETAILS

Figure 1 below identifies the joints.

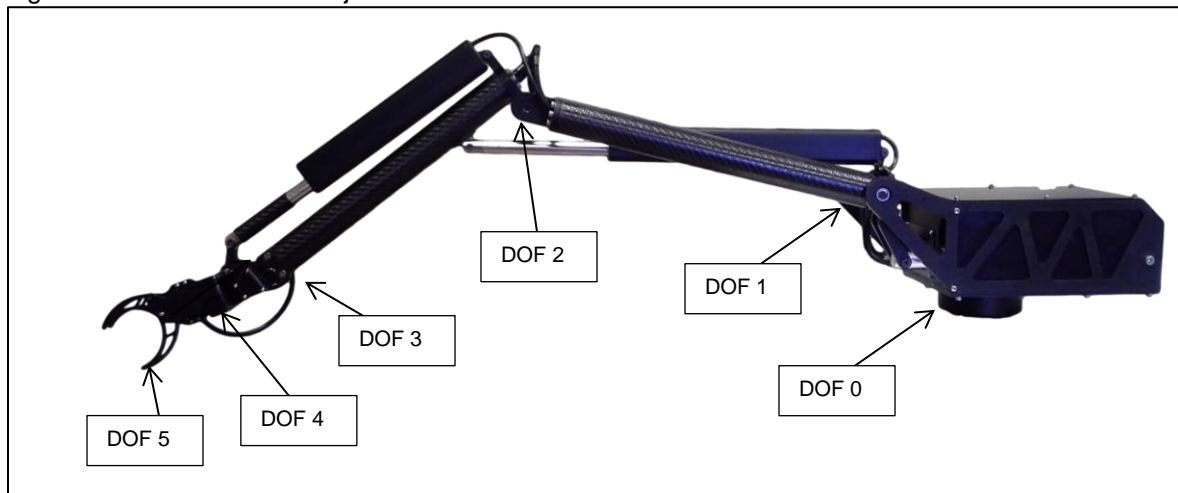

**Figure 1**

Following are the angles of travel of each Degree of Freedom:

### 6.1 DOF 0

DOF 0 is the "waist" rotational joint at the base of the ARM. It provides approximately 335 degrees of travel.

### 6.2 DOF 1

DOF 1 is the "shoulder lift" joint at the base of the ARM. It provides approximately 112 degrees of travel with 7 degrees below the horizon and 105 degrees above. Holds position with power off.



Page: 5	<b>ARM 3.0 Data Sheet</b>	Document Number: <b>i04207</b>
Total Pages: 8	Date: 2014/11/17	Revision: <b>02</b>

## 6.3 DOF 2

DOF 2 is the "elbow" joint. It provides approximately 120 degrees of travel. Holds position with power off.

## 6.4 DOF 3

DOF 3 is the "wrist pitch" joint. It provides approximately 95 degrees of travel. Holds position with power off.

## 6.5 DOF 4

DOF 4 is the "wrist rotate" joint. It provides approximately 320 degrees of travel. This DOF does not hold position with power off.

## 6.6 DOF 5

DOF 5 is the "gripper". It provides approximately 60 degrees of travel. This DOF does not hold position with power off.



Page: 6	<b>ARM 3.0 Data Sheet</b>	Document Number: <b>i04207</b>
Total Pages: 8	Date: 2014/11/17	Revision: <b>02</b>

## 7. DRAWING

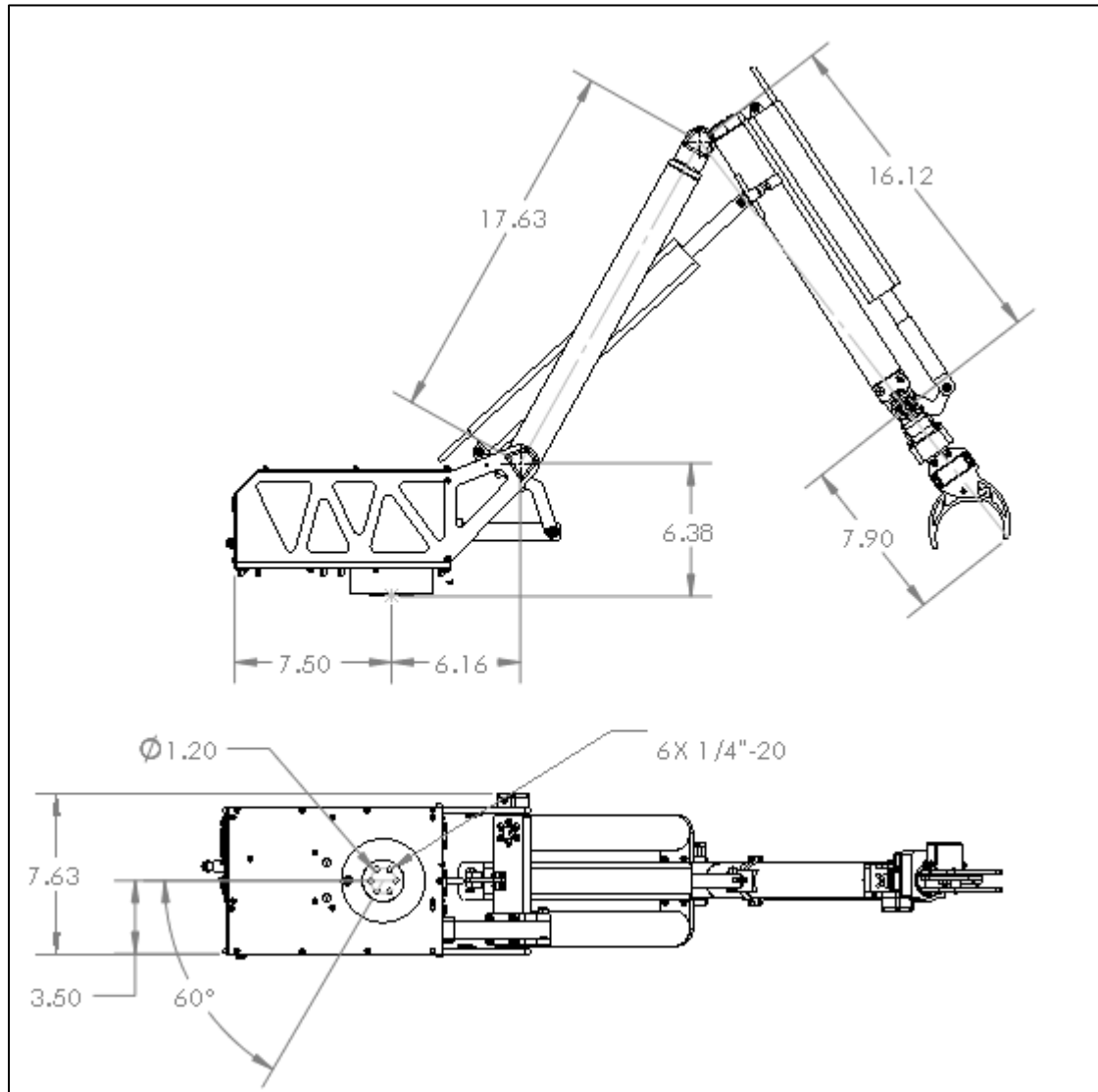

## 8. OPTIONAL EQUIPMENT

The following products are related to or accessories for this product.



Page: 7	<b>ARM 3.0 Data Sheet</b>	Document Number: <b>i04207</b>
Total Pages: 8	Date: 2014/11/17	Revision: <b>02</b>

Part Number	Description
i02035	Power Adapter, USB to Barrel Jack
i04251	AC to DC Inductive Rated Power Supply
i03813	6 Channel Simple Slider Controller
i03901	USB Maestro programmable controller

- Power Supply (Part Number i04251). Inductive rated power supply provides 12VDC at 4A continuous with peak surge to 12A. Input is 100-240 VAC 50-60Hz, 1.5A. Note that most bench top lab supplies will not handle the surges caused by the motors on the ARM.
- Internal blue-tooth radio module - Contact GearWurx for details
- Joint position feedback output - Contact GearWurx for details
- Motor current output - Contact GearWurx for details
- Additional custom wrist geometries - Contact GearWurx for details
- Pololu Maestro USB Controller (Part Number i03901). USB control interface with ability to create and save programs and sequences of movement.
- Simple Slider 6 Channel Controller (Part Number i03813)- This device allows precise control of the ARM 3.0 using equalizer style slide controls. Very intuitive. A wide range of slider and joystick controllers are also available at GearWurx.com

## 9. PACKAGING DETAILS

The following items are include in the package:

- ARM 3.0- Re-installation of two of the actuators is necessary as they are removed during shipping.
- Signal adapter cable is included to allow connection to Hobby RC type signal sources. The adapter cable also allows power connection to the ARM 3.0.

No power supply is included in the package.



Page: 8	<b>ARM 3.0 Data Sheet</b>	Document Number: <b>i04207</b>
Total Pages: 8	Date: 2014/11/17	Revision: <b>02</b>

## 10. CHANGE LOG

Revision	Date	Description of Changes
01	130617	Document Initial Release
02	141117	Update with significant new IO information